

REV	REVISION RECORD	DATE	DRWN	APVD
A	RELEASED (RD-2016-50)	08.DEC'16	KH	SJ
B	RELEASED (RD-2016-52)	20.DEC'16	KH	SJ

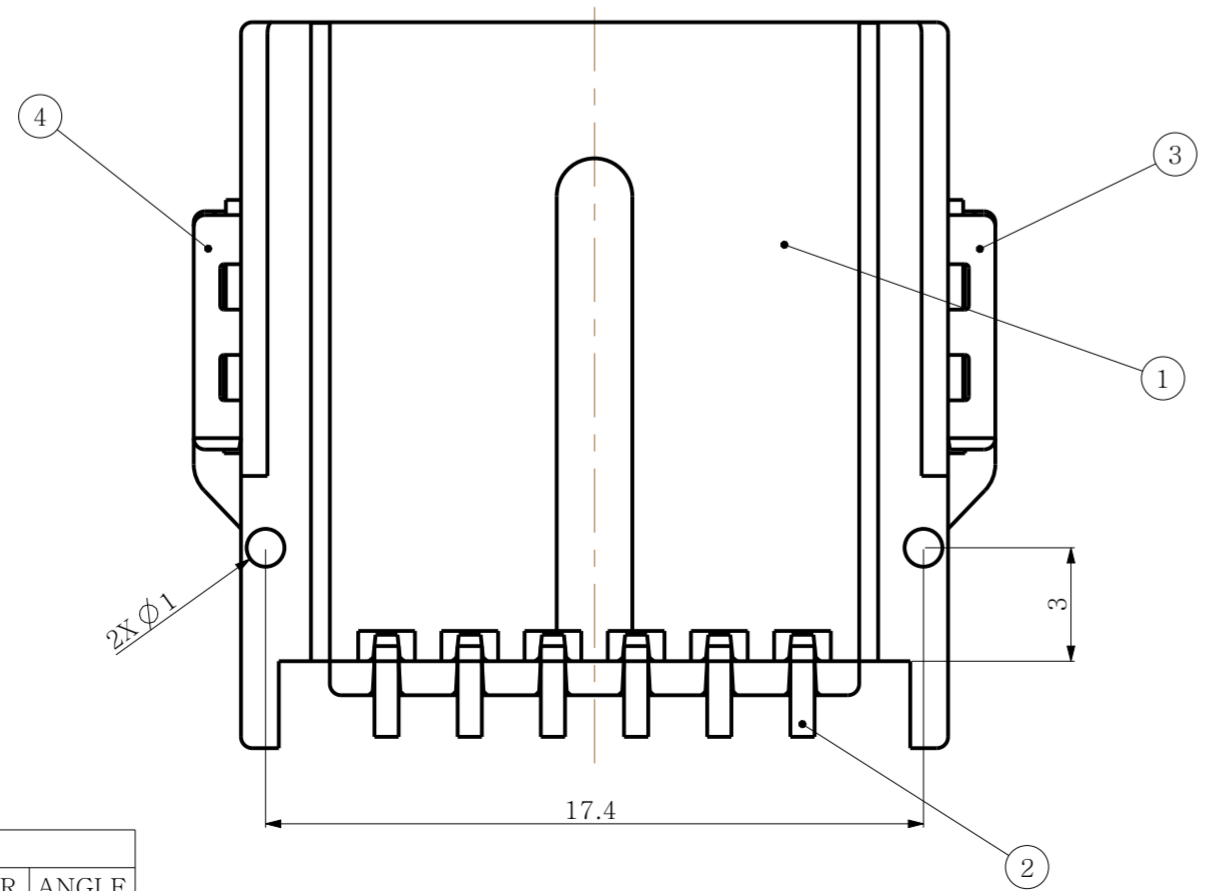
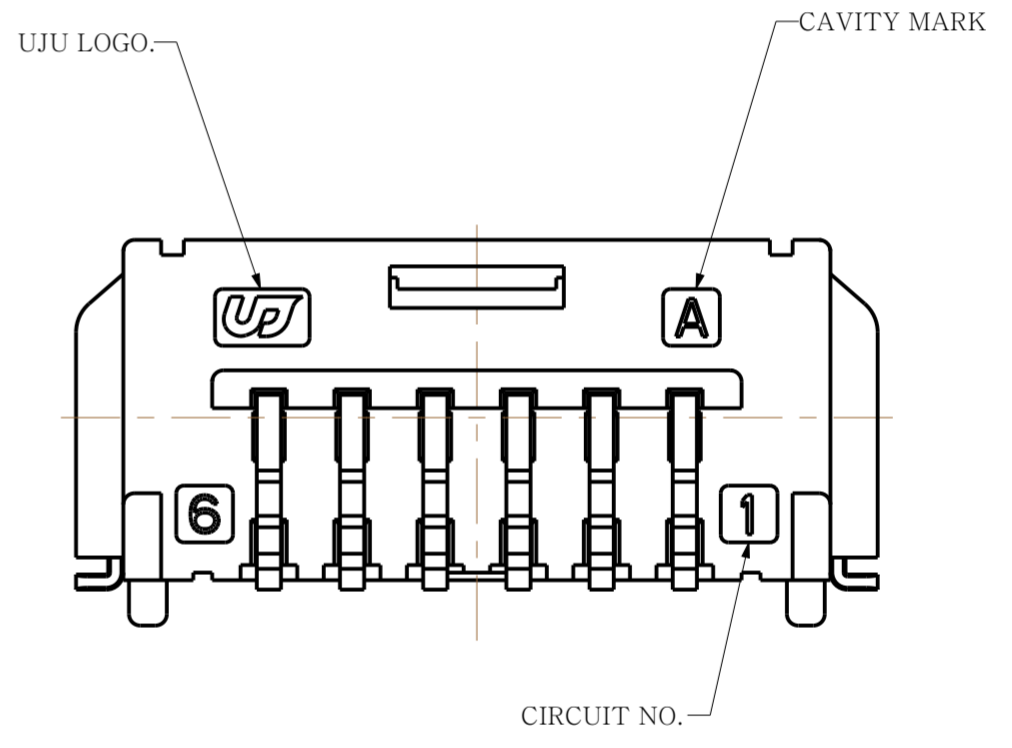
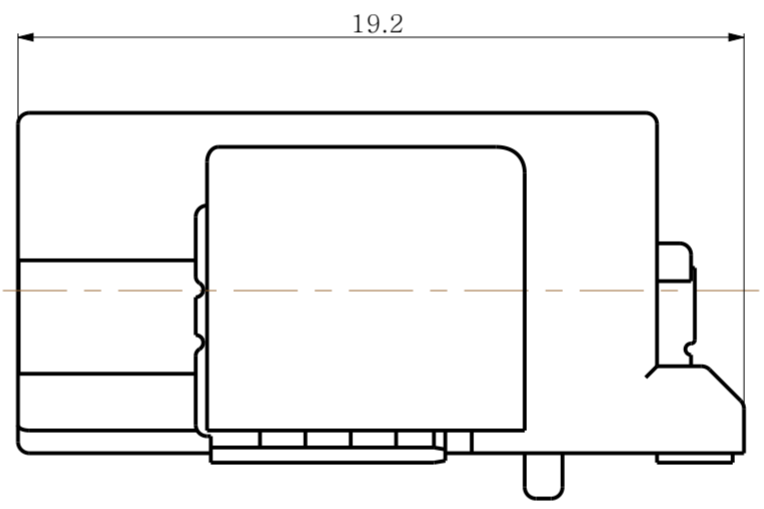
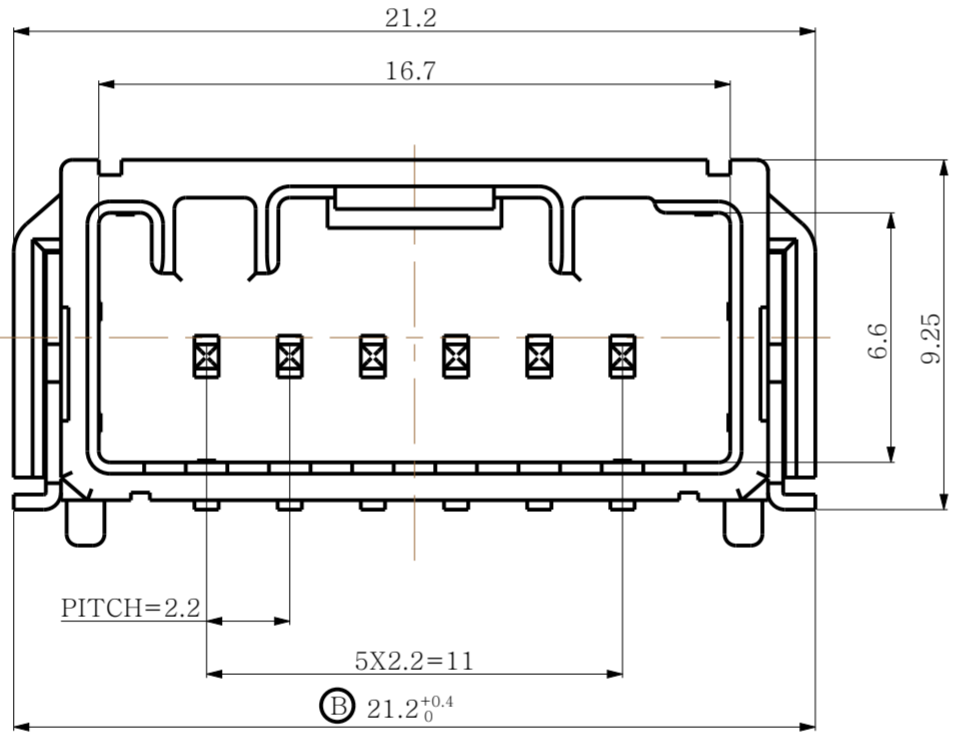
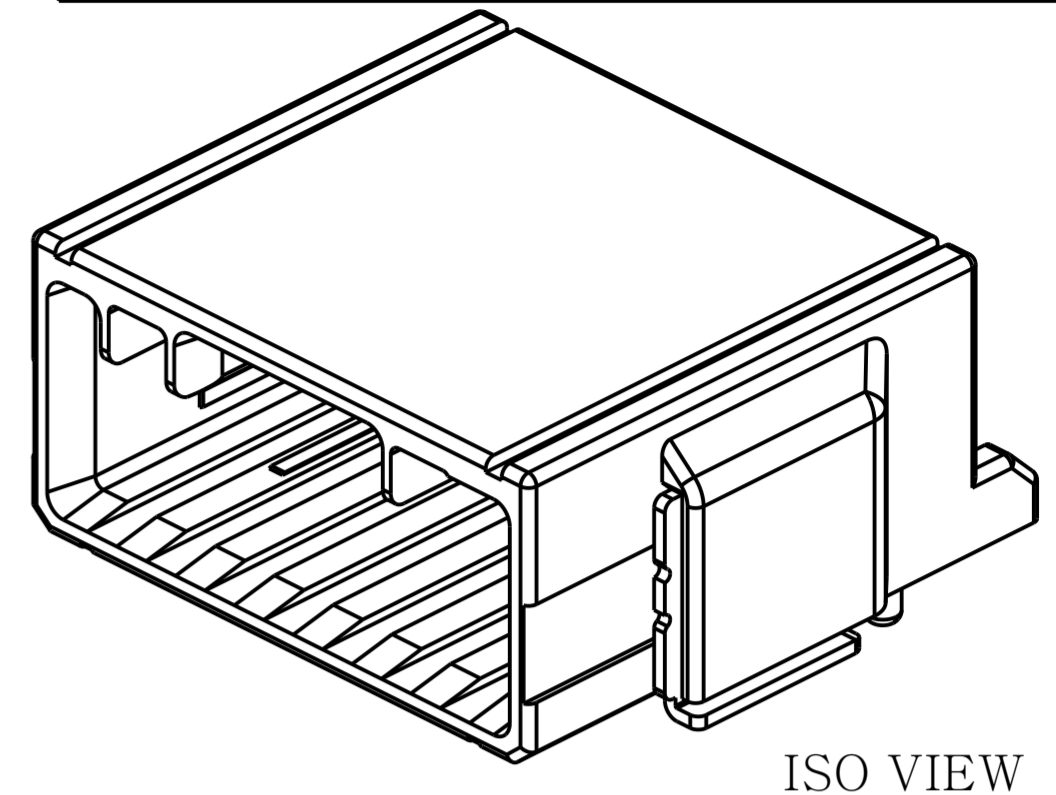
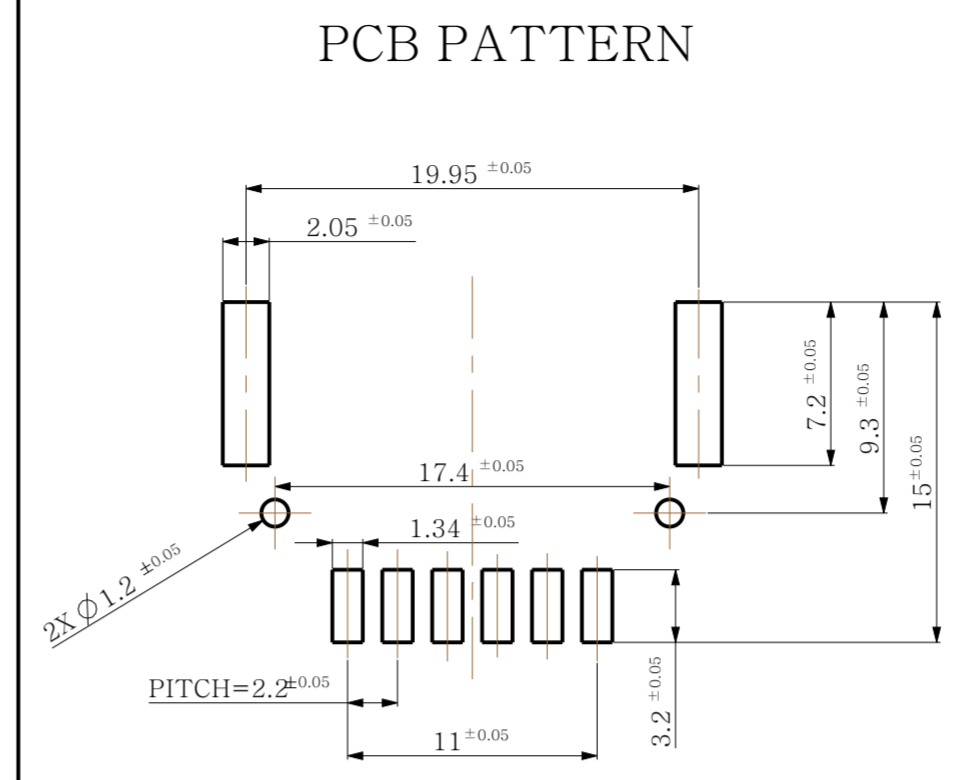
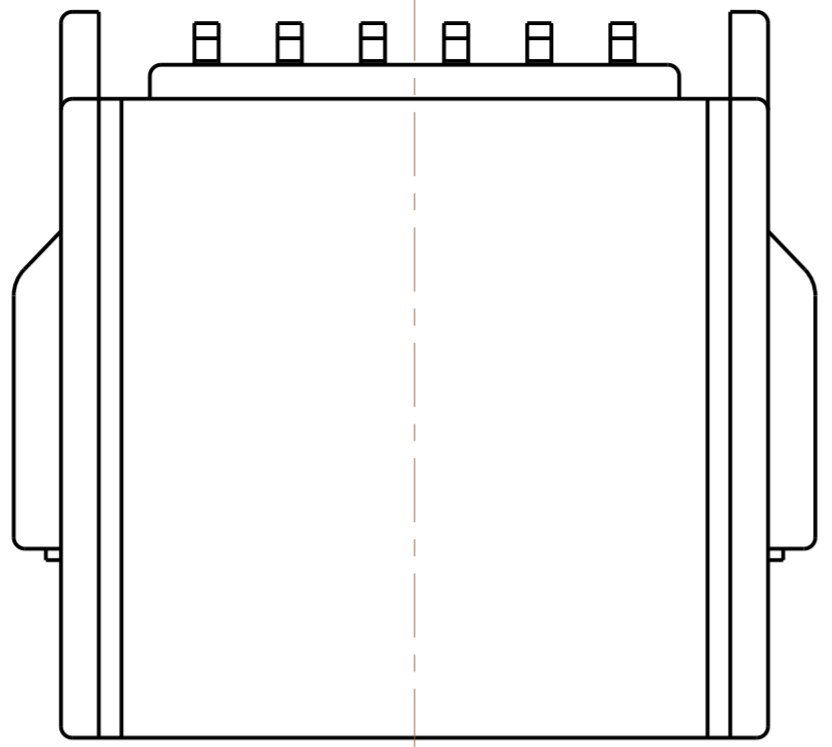
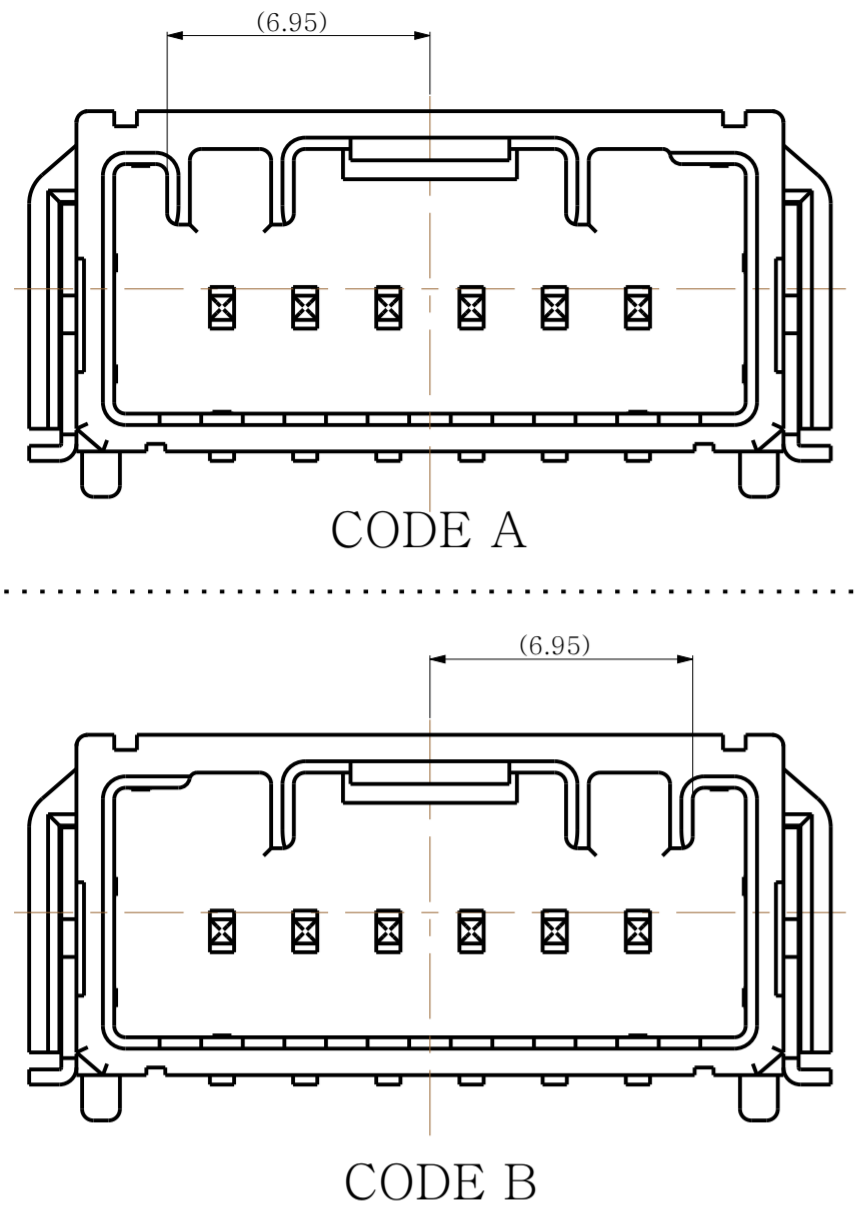

NOTE  
 1. General Tolerance : SEE TABLE TOLERANCE  
 2. HSG DESCRIPTION : SEE TABLE-1  
 3. MATERIAL  
 - HDR HSG : PPA-GF15  
 - SOLDER PEG : COPPER ALLOY (POST-TIN)  
 - TAB TML : COPPER ALLOY (POST-TIN)

TABLE-1

NO.	DESCRIPTION	PART NO.	CODE	MATERIAL	FINISH/COLOR	Q'TY	Q'TY
4	025 SMT SOLDER PEG-LEFT (HZT)	KM1300054-21	-	C2680-H	POST-TIN	1	1
3	025 SMT SOLDER PEG-RIGHT (HZT)	KM1300054-20	-		POST-TIN	1	1
2	025 SMT TAB TML (HZT)	KM1300053-20	-	C2680-H	POST-TIN	6	6
1	025 SMT 6M HDR HSG (HZT)	KM1300052-21	B	PPA GF15	BLACK	1	-
		KM1300052-10	A		NATURAL	-	1

ASSY DESCRIPTION	ASSY PART NO.	CODE
025 SMT 6M HDR ASSY (HZT)	KH1300051-21	B
025 SMT 6M HDR ASSY (HZT)	KH1300051-10	A

TOLERANCE							
10MAX	30MAX	50MAX	70MAX	100MAX	120MAX	250MAX	250VR
±0.15	±0.20	±0.30	±0.40	±0.50	±0.75	±0.9	±1.4
							ANGLE
							±0.5°

TOLERANCES UNLESS OTHERWISE SPECIFIED	UNIT MM	DRWN	KH.PARK		
		CHKD	CY.CHOI		
THIRD ANGLE PROJECTION	APVD	SJ.SONG			
		MATERIAL	SEE TABLE-1		
PRODUCT SPEC	APPLICATION SPEC	FINISH/COLOR	SEE TABLE-1		
		WEIGHT			
(주)우주 일렉트로닉스 UJU Electronics co.,Ltd.		NAME	025 SMT 6M HDR ASSY (HZT)		
DRAWING NO		KH1300051			
LOC	RESTRICTED TO	SIZE	SCALE	SHEET	REV
		A2	5:1	1	1 of B