

ASSEMBLY WITHOUT COVER

ASSEMBLY WITH COVER

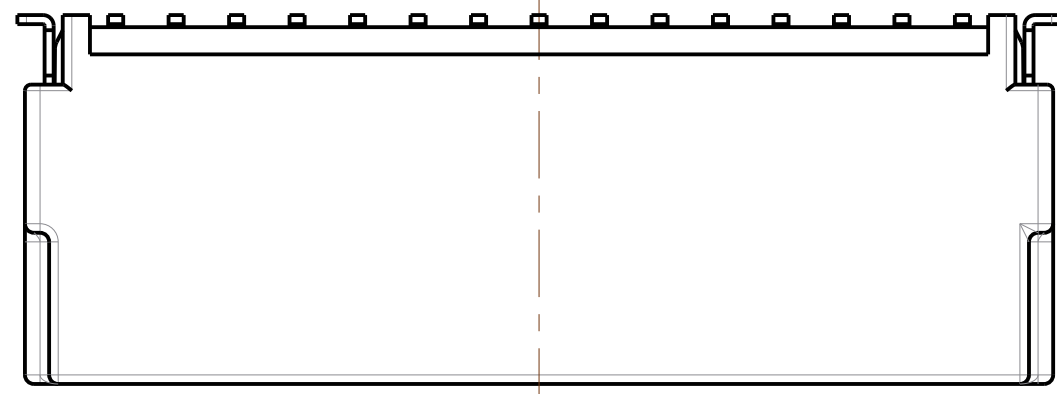

PCB PATTERN

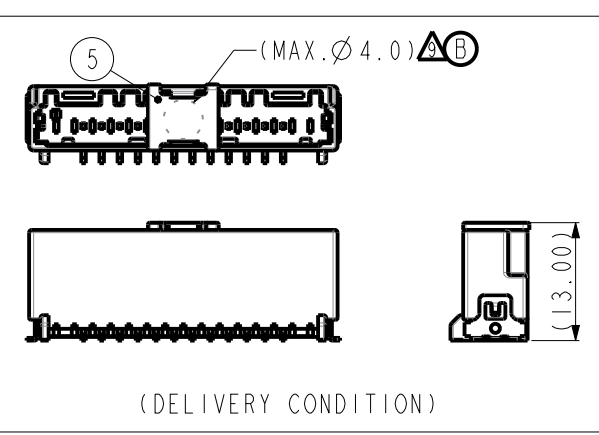
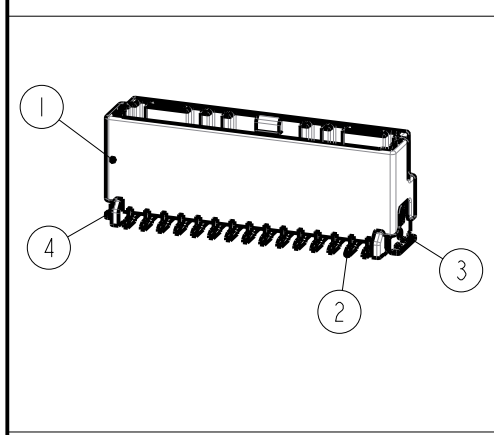
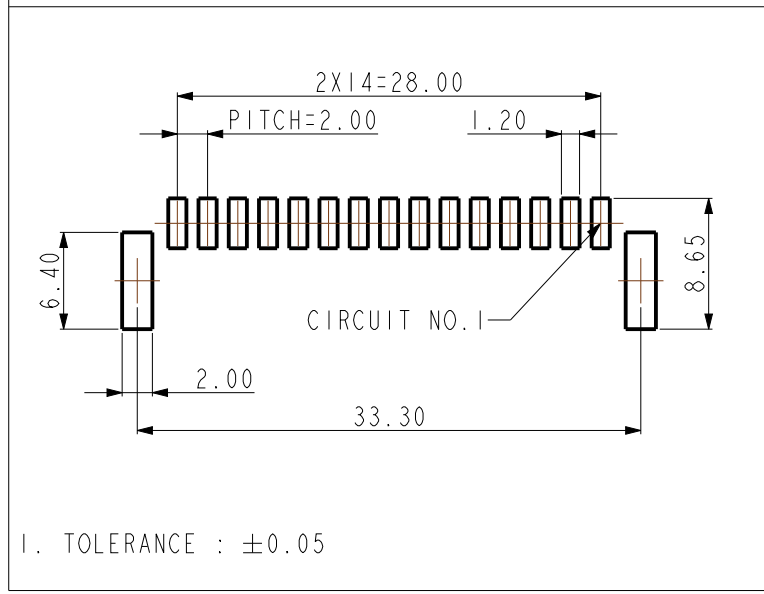

REV	REVISION RECORD	DATE	DRWN	CHKD	APVD
A	RELEASED	21. JUN '19	DR	KH	CY
B	REVISED (RD-2020-029)	09. MAR '20	DR	KH	CY
C	REVISED (RD-2020-140)	23. OCT '20	DR	KH	CY

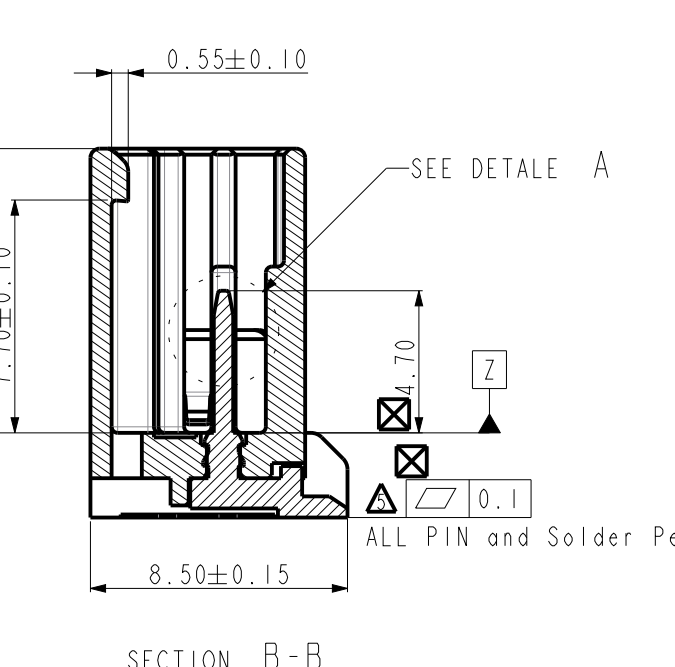
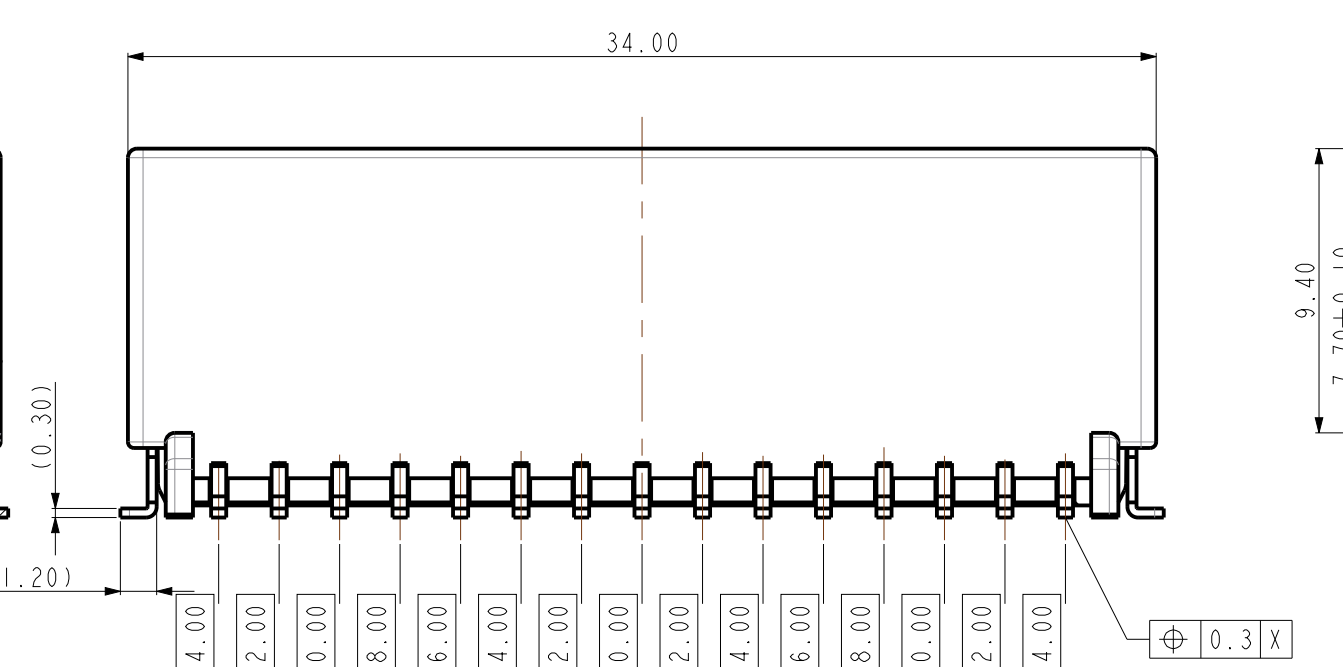
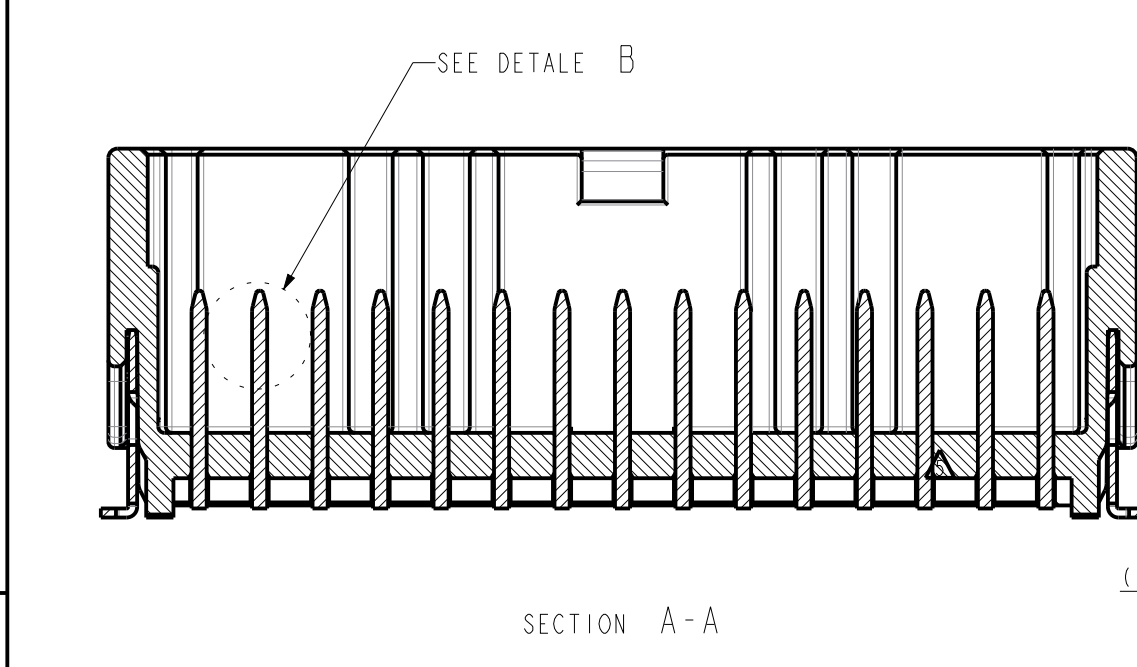
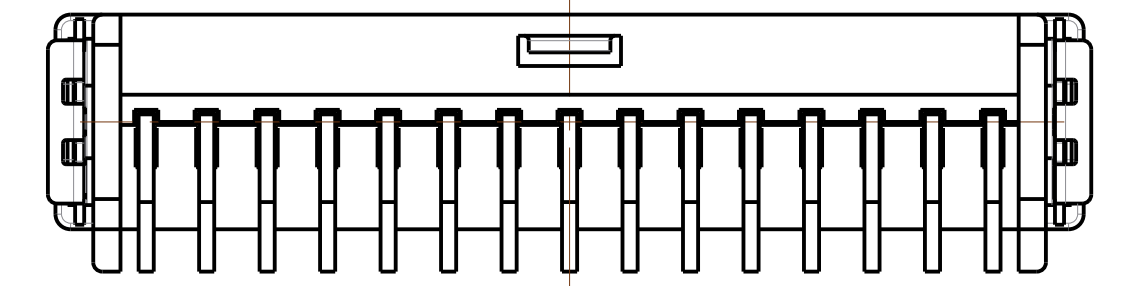
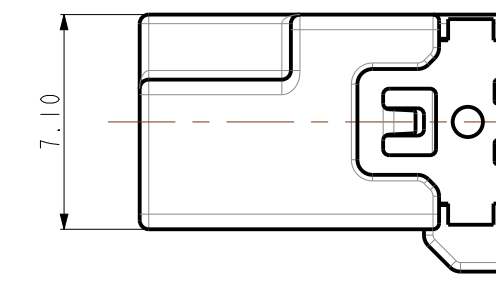
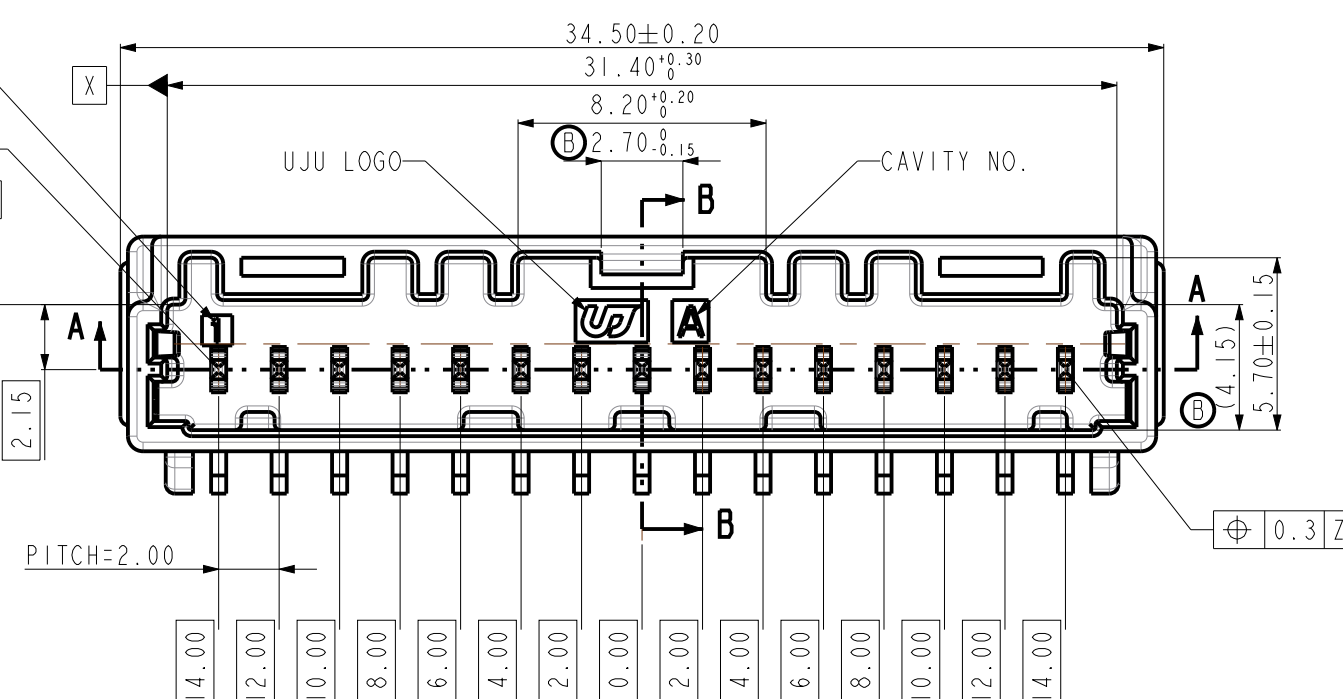
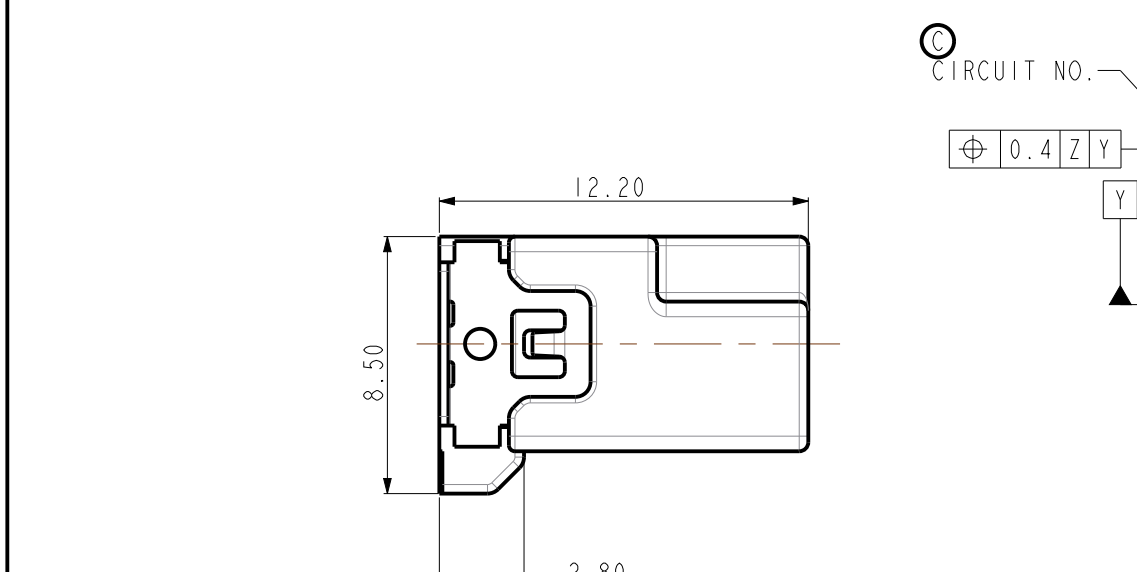
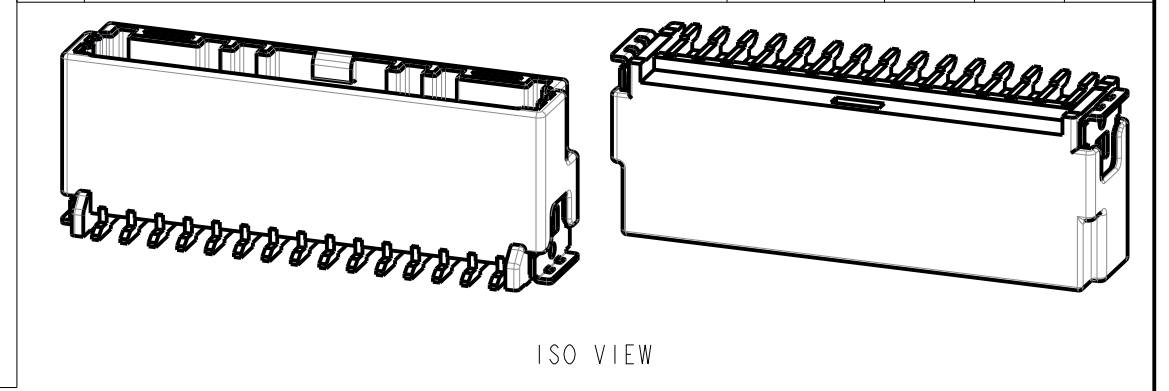

NOTE.

- GENERAL TOLERANCE : REFER TO DIN16742 T65 SPECIFICATION
- BURR 0.3 MAX.
- NO CRACK
- ALL LETTERS SHALL BE CLEAR AND LEGIBLE
- MEASURING THE DIMENSIONS OF TAB TML AND SOLDER PEG.
- FINISH TAB TML AND SOLDER PEG
TIN PLATING 2.0-4.0um MATTE
OVER NICKEL PLATING 0.8-2.0um MATTE
- PACKING : EMBOSS TAPE
- FLAMMABILITY : UL94 - HB
- VACUM GRIP AREA FREE OF BURR AND FECTOR PINS. MAX Ø4.0mm

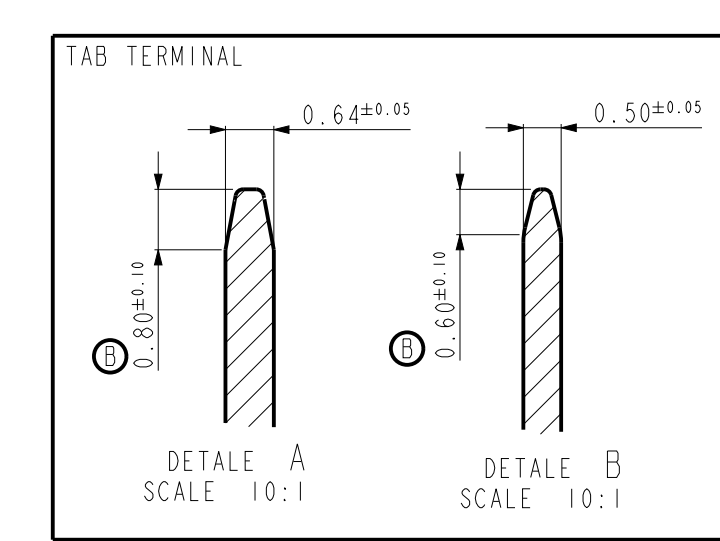
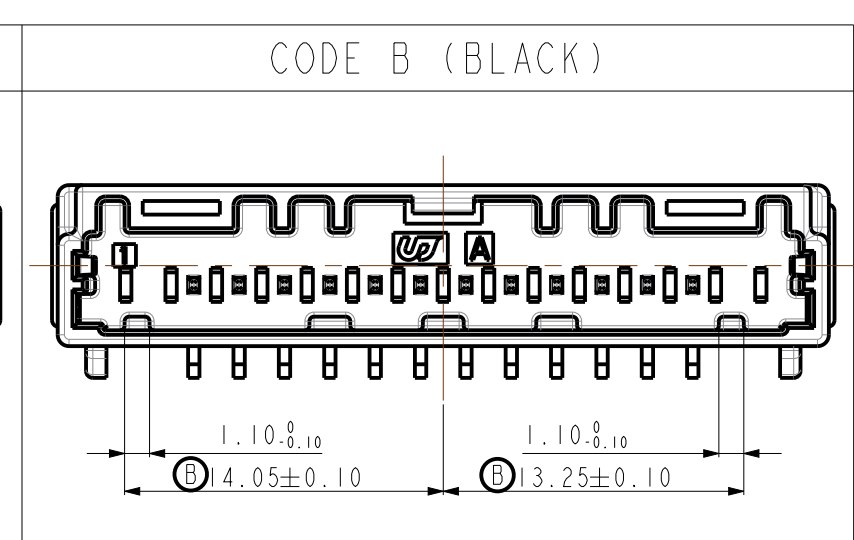
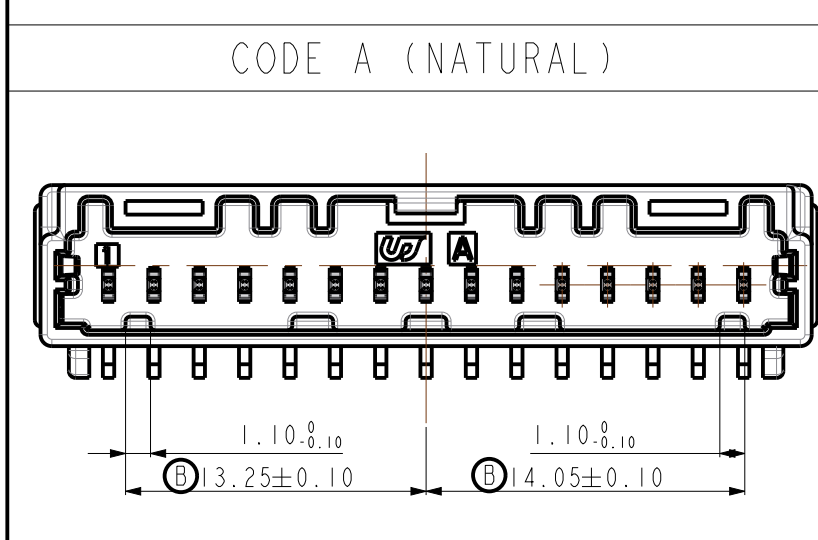

NO	DESCRIPTION	MATERIAL	FINISH/COLOR	Q'TY
⑤	020_D_COVER_HSG_BK	LCP (E471i)	BLACK	1
④	020_SMT_SOLDER_PEG-LEFT (VTC)	BRASS	POST-TIN	1
③	020_SMT_SOLDER_PEG-RIGHT (VTC)	BRASS	POST-TIN	1
②	020_SMT_TAB_TML (VTC)	BRASS	POST-TIN	15
①	020_D_SMT_15M_V_HSG_BK	PA9T GF30	BLACK	1
①	020_D_SMT_15M_V_HSG_NR	PA9T GF30	NATURAL	1

DRWN	DR KOO	(주)우주 일렉트로닉스 UJU Electronics co.,Ltd.	NAME			
CHKD	KH PARK		020_D_SMT_15M_V_ASSY_G			
APVD	CY CHOI		DRAWING NO			
MATERIAL	SEE TABLE	CUSTOMER	DRAWING			
FINISH/COLOR	SEE TABLE	LOC	RESTRICTED TO	SIZE	SCALE	
WEIGHT	-	-	-	A2	4:1	
PRODUCT SPEC	-	APPLICATION SPEC	-	SHEET	1 OF 1	
				REV	C	