

REV	REVISION RECORD	DATE	DRWN	CHKD	APVD
A	REVISED(RD-2019-060)	2019.04.15	KH	-	CY

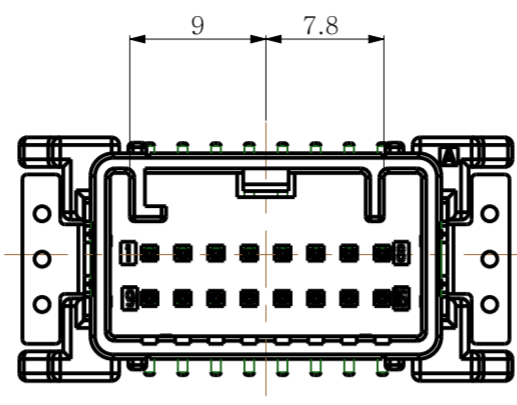

CODE A

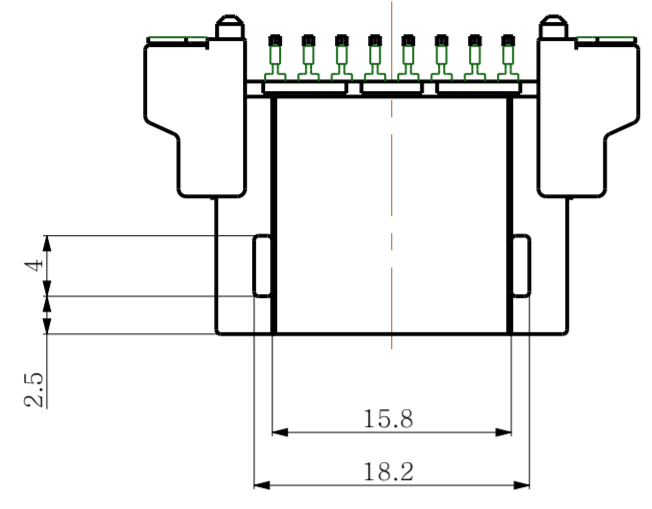
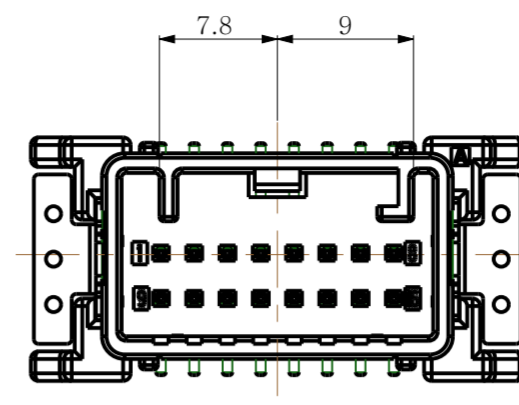

CODE B

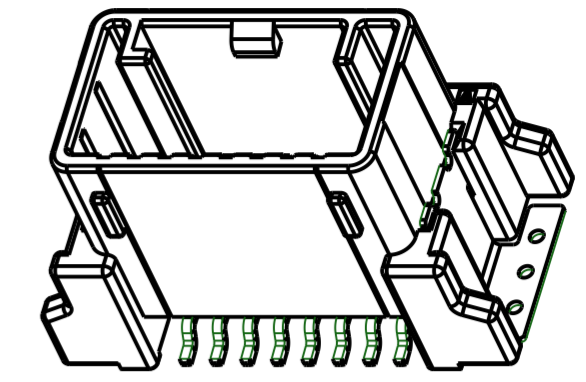

3D VIEW

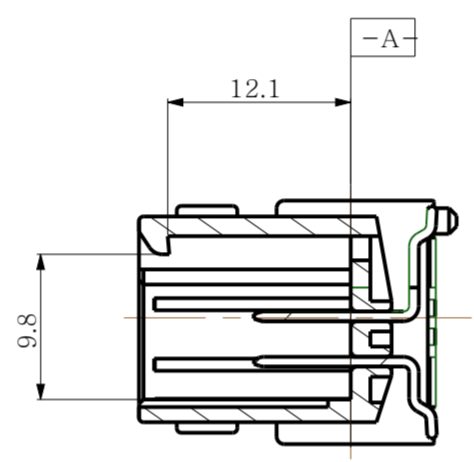
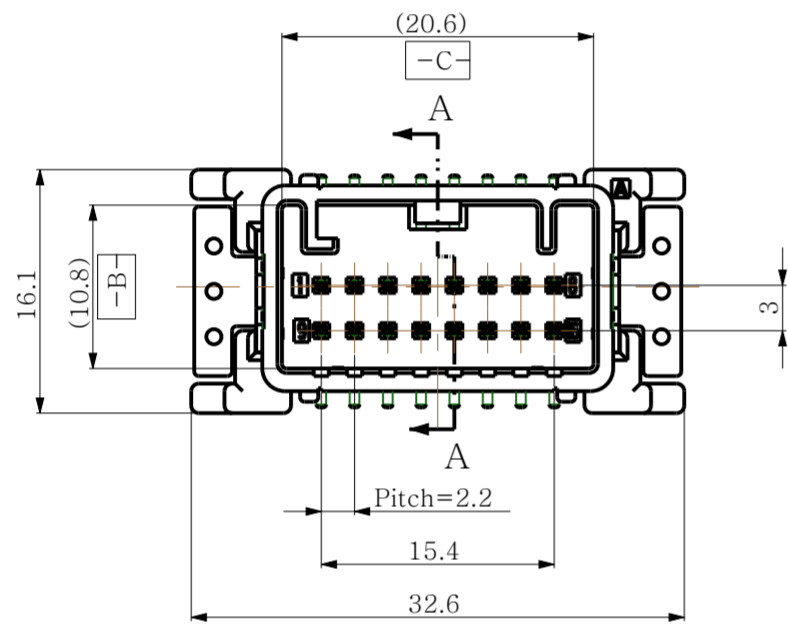

SECTION A-A

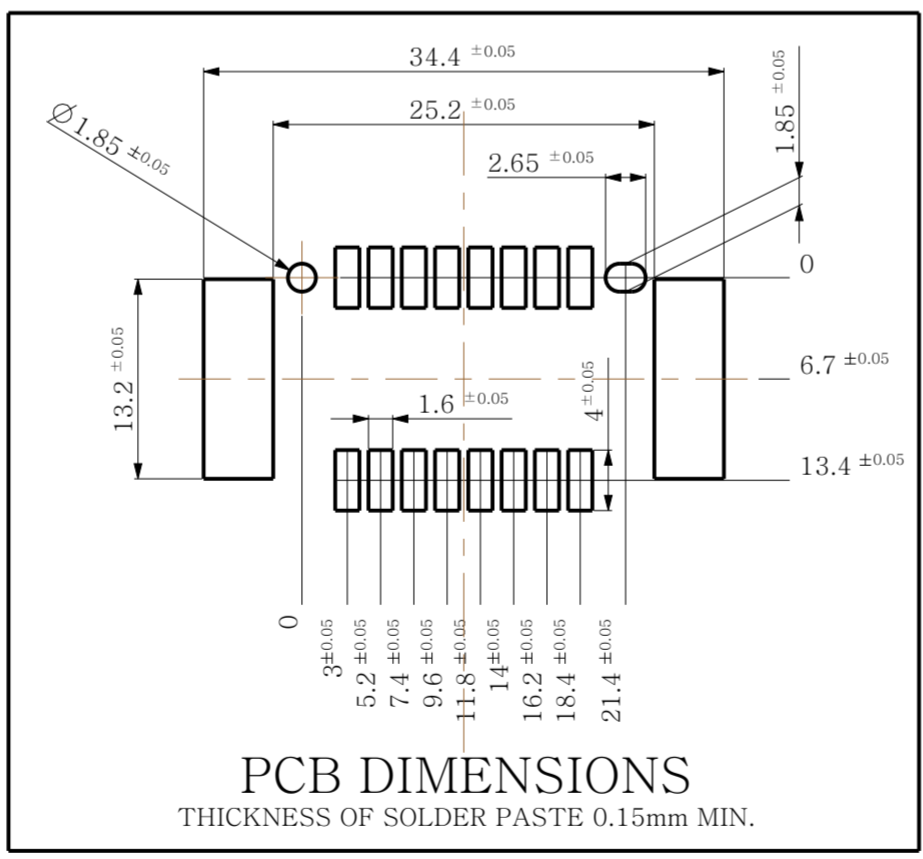
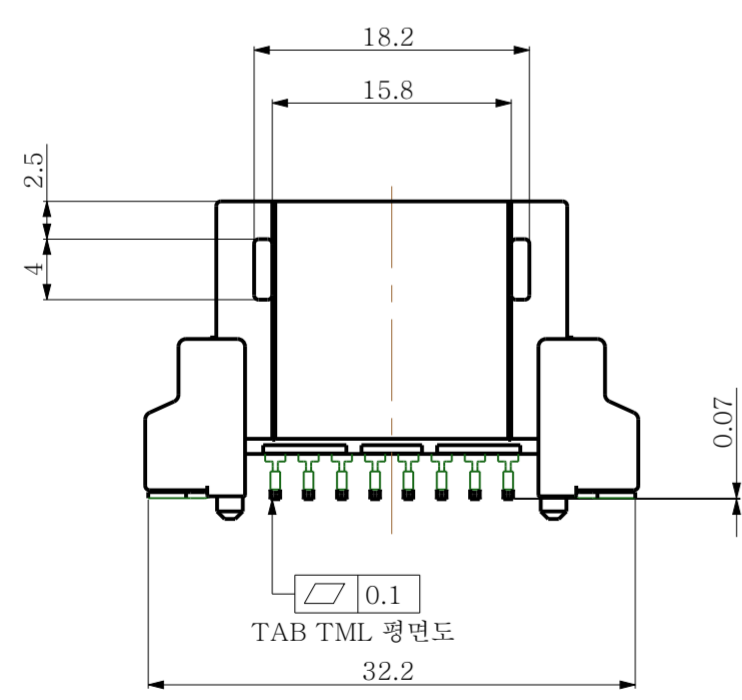
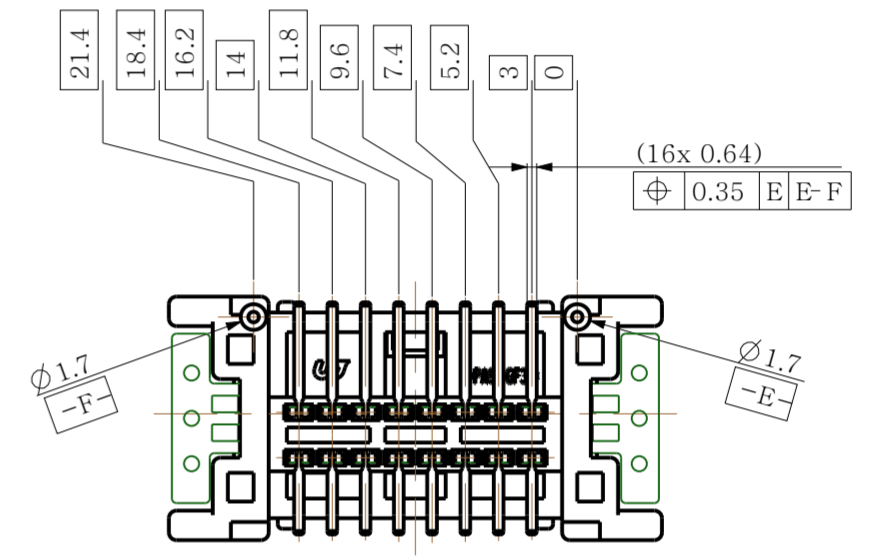
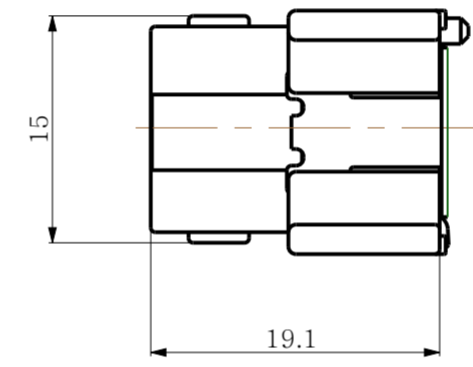

NOTE.
1. BURR SIDE IS NOT PERMITTED.
2. NO CRACK.

NO.	DESCRIPTION	PART NO.	CODE	MATERIAL	FINISH/COLOR	Q'TY	Q'TY
4	TR_SMT_V_SPeg_L	KM1700074-20	-	BRASS	POST-TIN	2	2
3	025_TR_SMT_V_TAB_L_POT	KM1700073-20	-	BRASS	POST-TIN	8	8
2	025_TR_SMT_V_TAB_S_POT	KM1700072-20	-	BRASS	POST-TIN	8	8
1	025_TR_SMT_16M_V_HSG_BK	KM1700071-21	B	PA9T-GF33	BLACK	1	-
	025_TR_SMT_16M_V_HSG_NR	KM1700071-10	A	PA9T-GF33	NATURAL	-	1

DESCRIPTION	ASSY PART NO.	CODE
025_TR_SMT_16M_V_ASSY_BK	KH1700070-21	B
025_TR_SMT_16M_V_ASSY_NR	KH1700070-10	A

TOLERANCE								
10MAX	30MAX	50MAX	70MAX	100MAX	120MAX	250MAX	250VR	ANGLE
±0.15	±0.20	±0.30	±0.40	±0.50	±0.75	±0.9	±1.4	±0.5도

TOLERANCES UNLESS OTHERWISE SPECIFIED 0 ± 0.0 ± 0.00 ± 0.000 ± 0.0000 ± ANGLES ±	UNIT MM	THIRD ANGLE PROJECTION	DRWN KH.PARK	(주)우주일렉트로닉스 UJU Electronics co.,Ltd.
	PRODUCT SPEC	APPLICATION SPEC	CHKD -	
APVD CY.CHOI		MATERIAL SEE TABLE	NAME 025_TR_SMT_16M_V_ASSY	
FINISH/COLOR SEE TABLE		CUSTOMER DRAWING	DRAWING NO KH1700070	
WEIGHT		LOC	RESTRICTED TO	SIZE A2
		SCALE 2:1	SHEET 1 OF 1	REV A

D

C

B

A