

REV	REVISION RECORD	DATE	DRWN	CHKD	APVD
B	REVISED(RD-2014-005)	22MAY'14	CH	-	SJ
C	REVISED(RD-2015-010)	26FEB'15	CH		SJ
D	REVISED(RD-2020-080)	18JUN'20	KH	KH	CY

TPA LOCKING POSITION

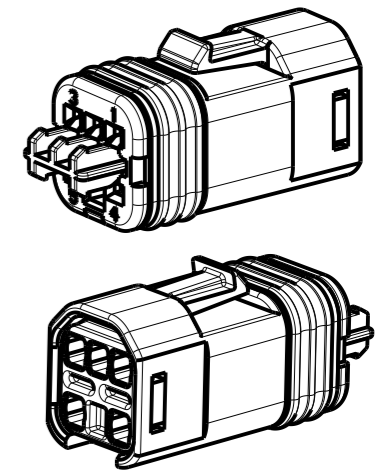

3D VIEW

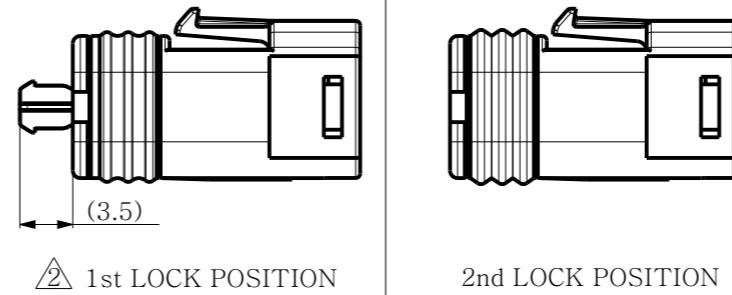
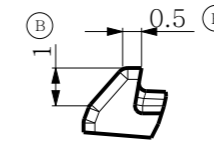
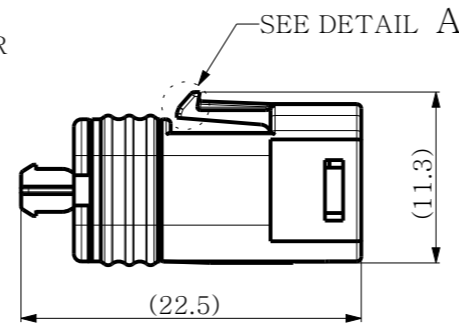
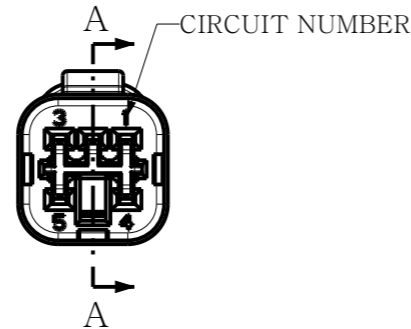
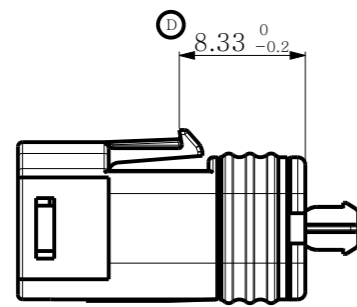
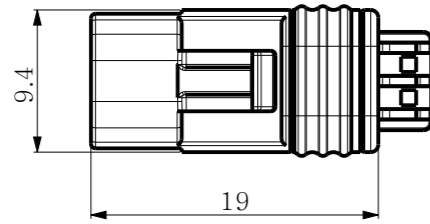

DETAIL A
SCALE 5:1

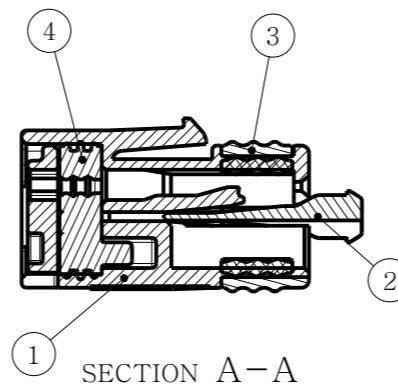
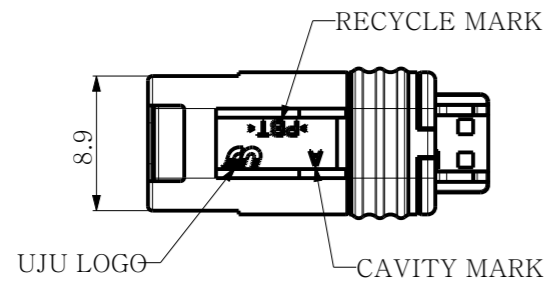

SECTION A-A

NOTE
 1. GENERAL TOLERANCE: ±0.3, ±3°
 2. DELIVERY CONDITION: TPA FIRST LOCK POSITION
 3. APPLICABLE RECEPTACLE TERMINAL: <TABLE 1>

NO	DESCRIPTION	MATERIAL	COLOR	ASSY P/N	REV
④	030 SLD 5F Block Seal	SILICONE	RED	1	
③	030 SLD 5F Inner Seal	SILICONE	RED	1	
②	③ 030 SLD 5F TPA HSG	PBT-GF15	NATURAL	1	
①	030 SLD 5F HSG	PBT	BLACK	1	

<TABLE 1>

CONTACT	.030 FEMALE TML (TYCO)
P/N	917308-1
WIRE SIZE(mm ²)	0.3~0.5

TOLERANCES UNLESS OTHERWISE SPECIFIED	UNIT
0	±
0.0	±
0.00	±
0.000	±
0.0000	±
ANGLES	±
PRODUCT SPEC	APPLICATION SPEC
-	-

DRWN CH.PARK	(주)우주 일렉트로닉스 UJU Electronics co.,Ltd.			
CHKD YD.LEE				
APVD SJ.SONG	NAME			
MATERIAL	030 SLD 5F ASS'Y			
SEE TABLE	CUSTOMER		DRAWING NO	
FINISH/COLOR	DRAWING		KH1200043	
SEE TABLE	LOC	RESTRICTED TO	SIZE	SCALE
WEIGHT	-	-	A3	2/1
			SHEET	REV
			1	D